

WINTER – 19 EXAMINATION

Subject Name: Engineering Drawing

Model Answer

Subject Code: 22207

Important Instructions to examiners:

- 1) The answers should be examined by key words and not as word-to-word as given in the model answer scheme.
- 2) The model answer and the answer written by candidate may vary but the examiner may try to assess the understanding level of the candidate.
- 3) The language errors such as grammatical, spelling errors should not be given more Importance (Not applicable for subject English and Communication Skills).
- 4) While assessing figures, examiner may give credit for principal components indicated in the figure. The figures drawn by candidate and model answer may vary. The examiner may give credit for any equivalent figure drawn.
- 5) Credits may be given step wise for numerical problems. In some cases, the assumed constant values may vary and there may be some difference in the candidate's answers and model answer.
- 6) In case of some questions credit may be given by judgement on part of examiner of relevant answer based on candidate's understanding.
- 7) For programming language papers, credit may be given to any other program based on equivalent concept.

Q. No.	Sub Q. N.	Answer	Marking Scheme
Q. 1 (A)	a)		02 Marks
	b)		01 Mark each

c)		02 Marks
d)		01 Mark each
e)		02 Marks
f)		02 Marks
g)		02 Marks

Q.
2

a)

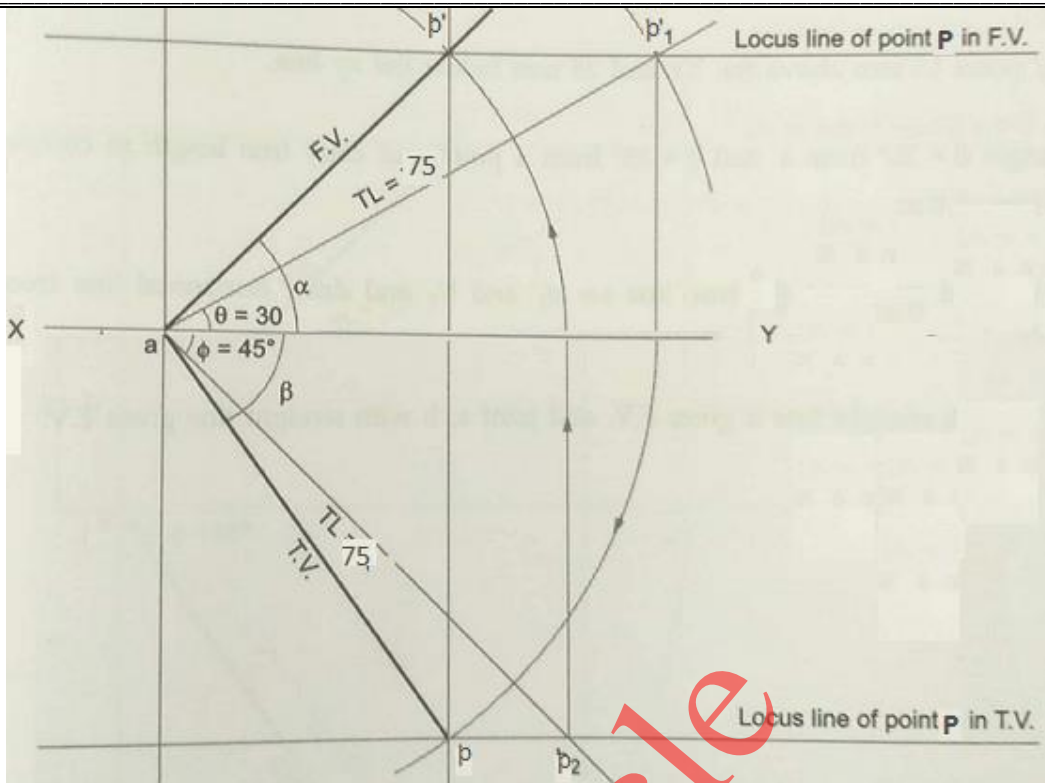

04
Marks
FV -02
TV-02

b)

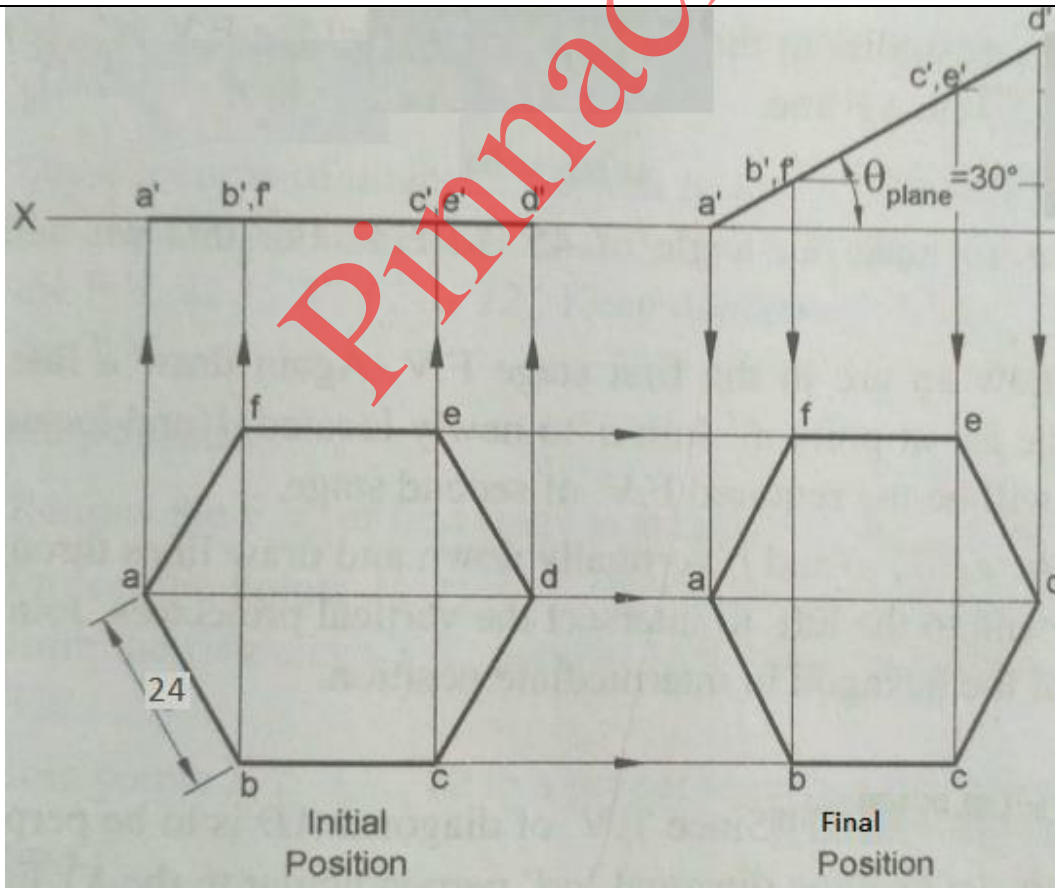

Initial
Position 02
marks
Final
Position 02
marks

c)

Initial Position 02 marks
Final Position 02 marks

d)

Initial Position 02 marks
Final Position 02 marks



e)	<p>The diagram illustrates the projections of a line. The front view is a vertical line segment labeled 1'a'2'3'. The top view is a triangle with vertices labeled a,1, b,2, and c,3. The auxiliary view shows the true shape of the line as a trapezoid with vertices labeled a1, b1, c1, 21, 31, 11. The line is inclined to the XY line.</p>	Initial Position 02 marks Final Position 02 marks
----	---	--

Pinnacle



Q. 3

a)

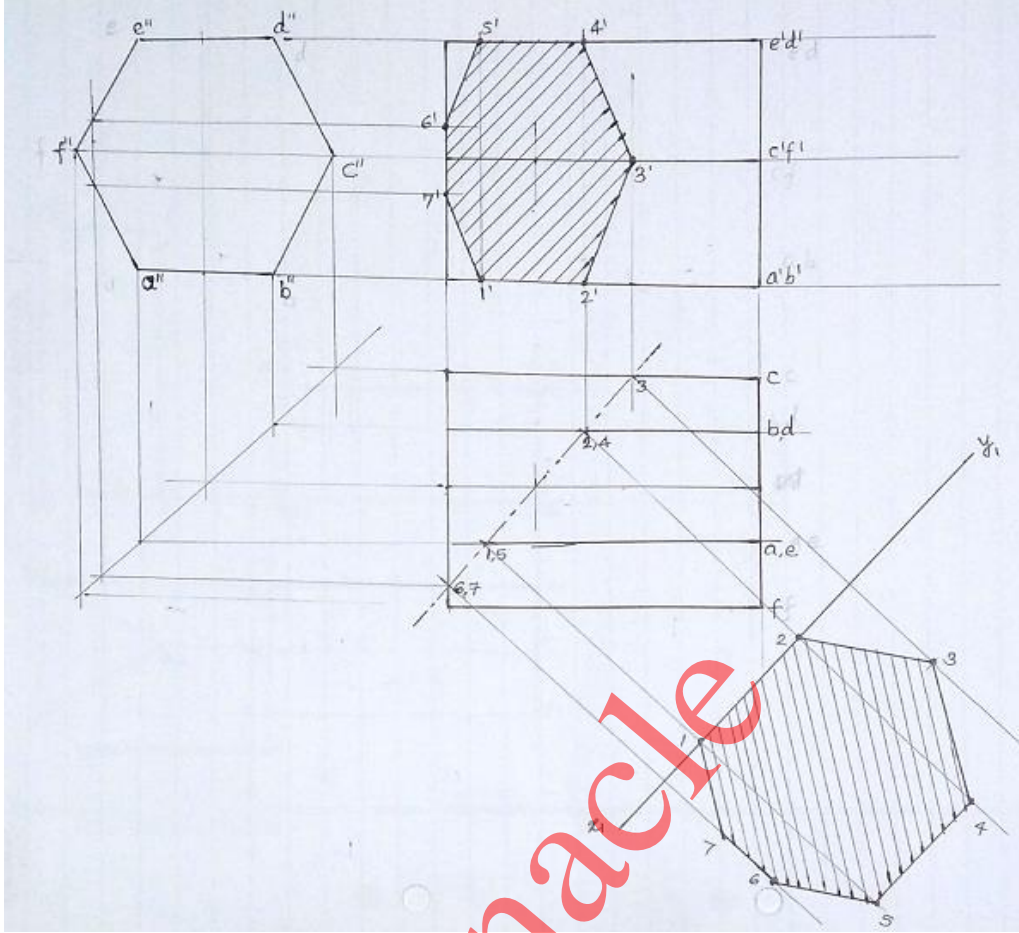

T.V. 02
Marks,
S.F.V.
03
Marks,
True
shape
of
section
03
Marks

b)

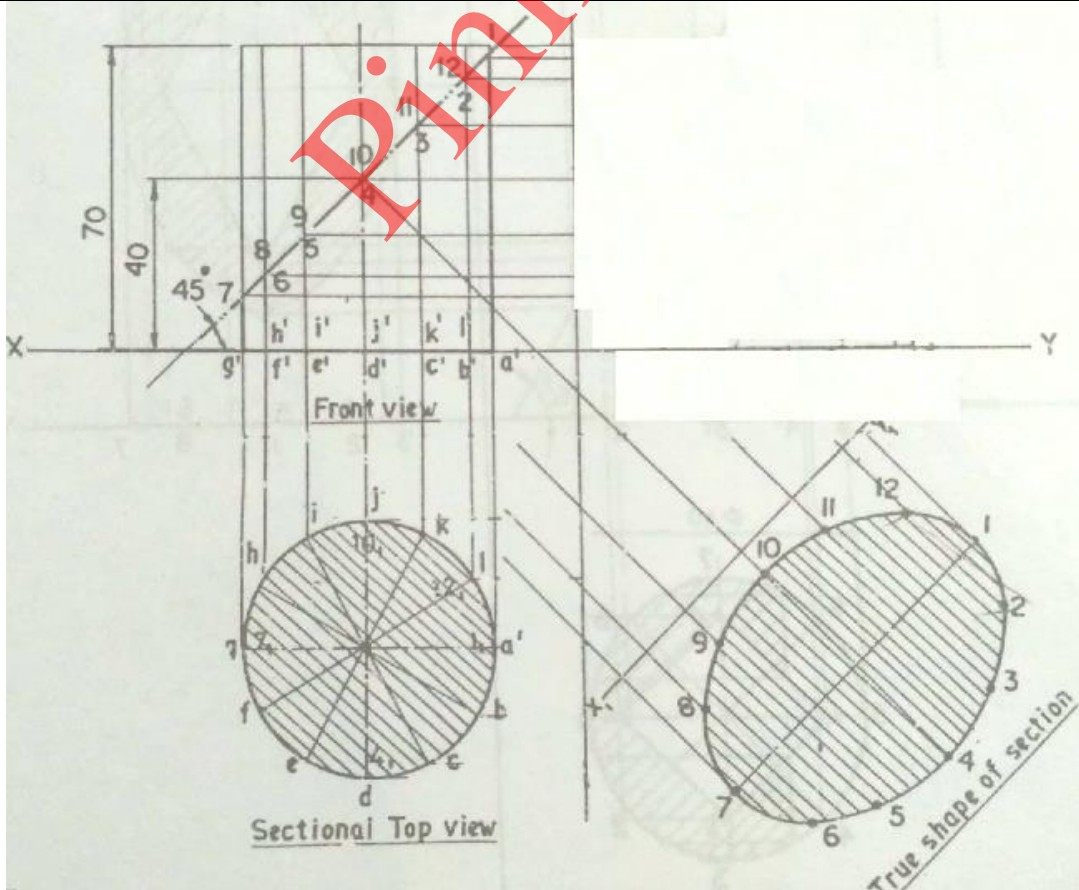

F.V. 02
Marks,
S.T.V.
03
Marks,
True
shape
of
section
03
Marks

OUR CENTERS :

KALYAN | DOMBIVLI | THANE | NERUL | DADAR
Contact - 9136008228

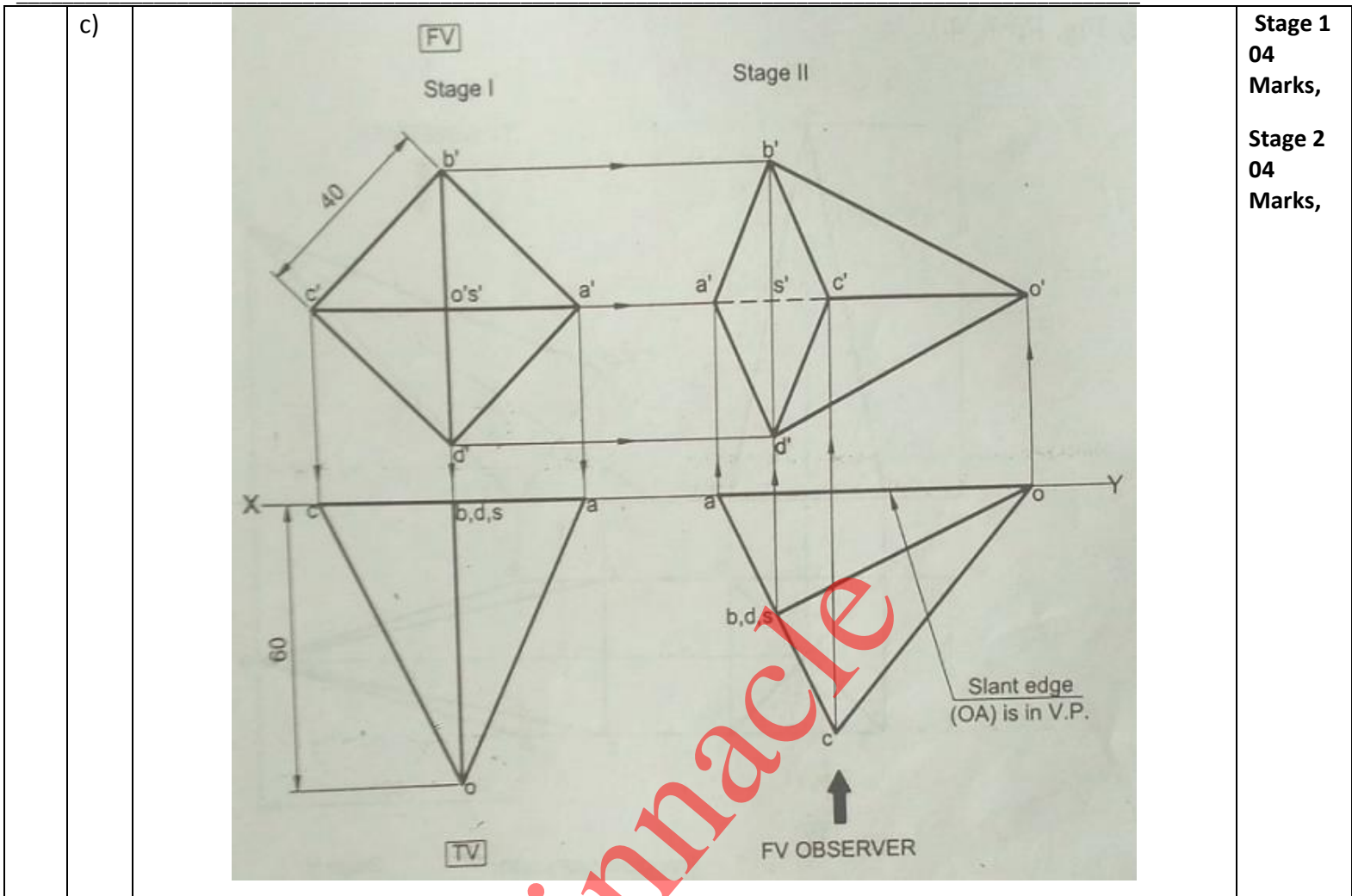

Stage 1
04
Marks,

Stage 2
04
Marks,

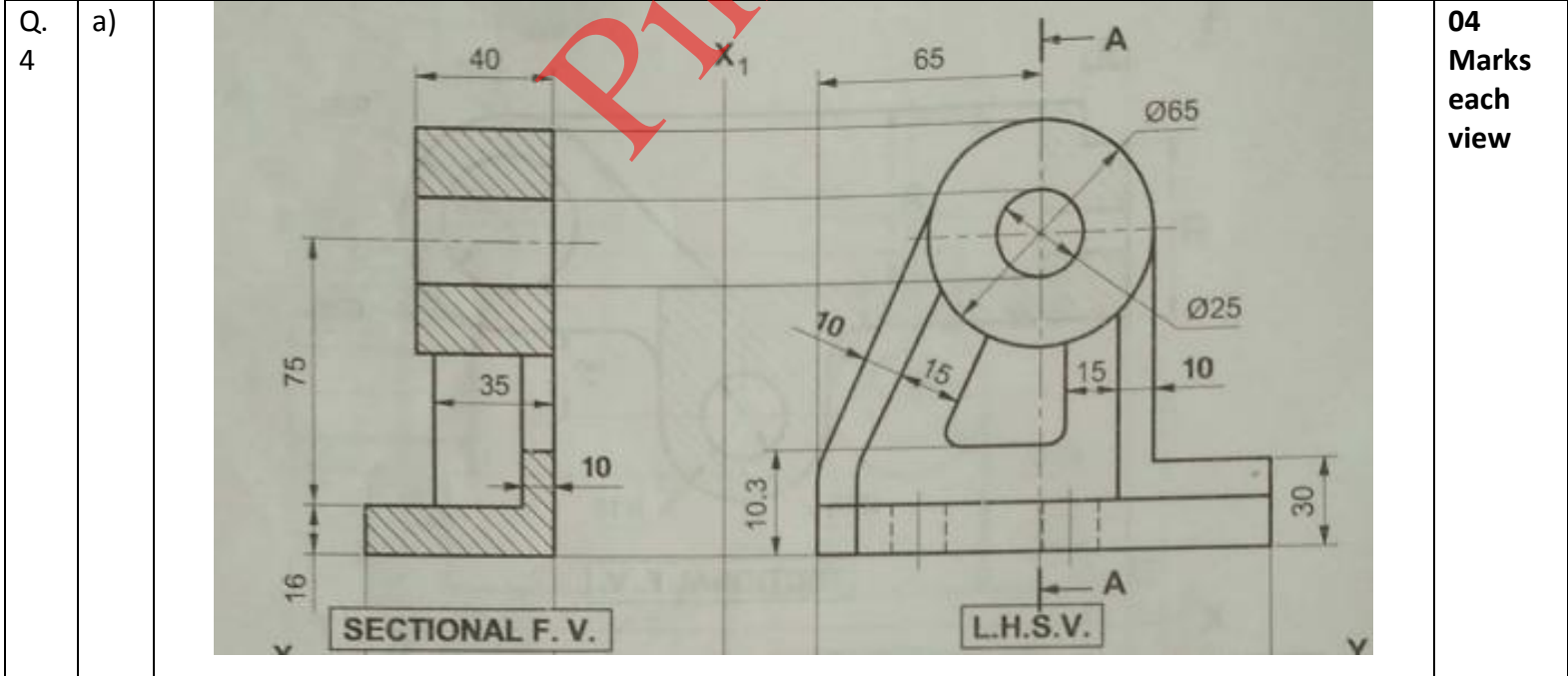

04
Marks
each
view

b)

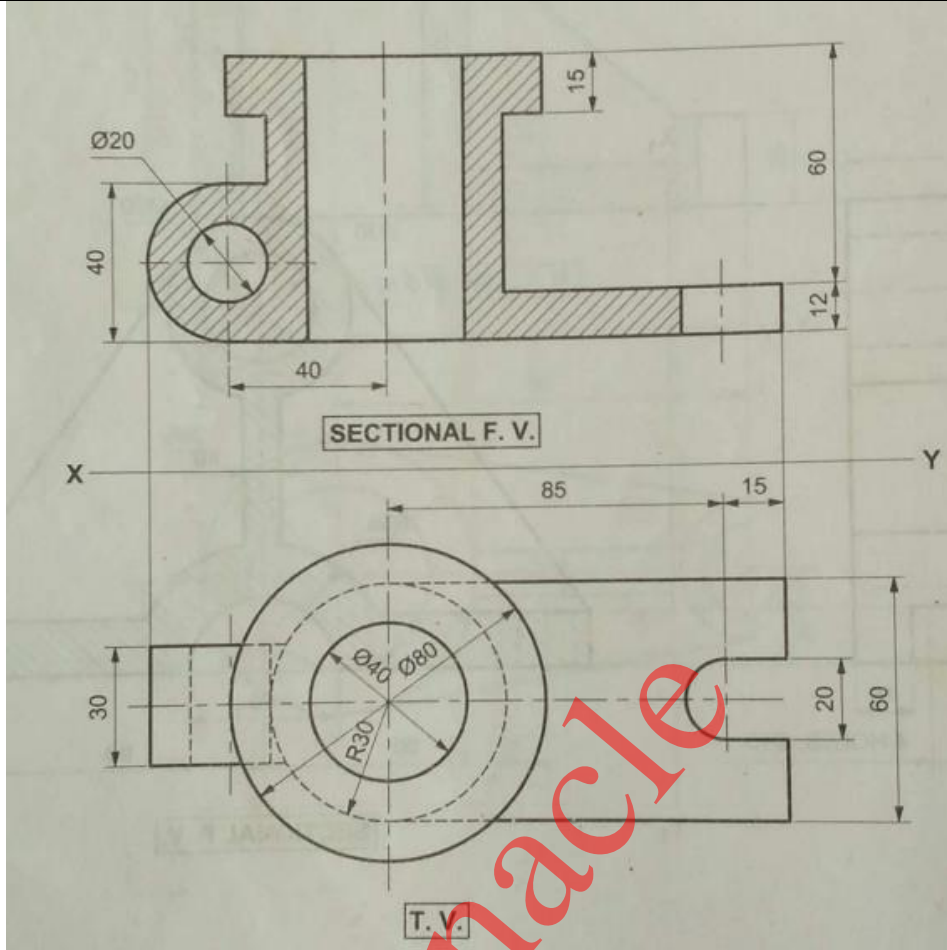

04
Marks
each
view

c)

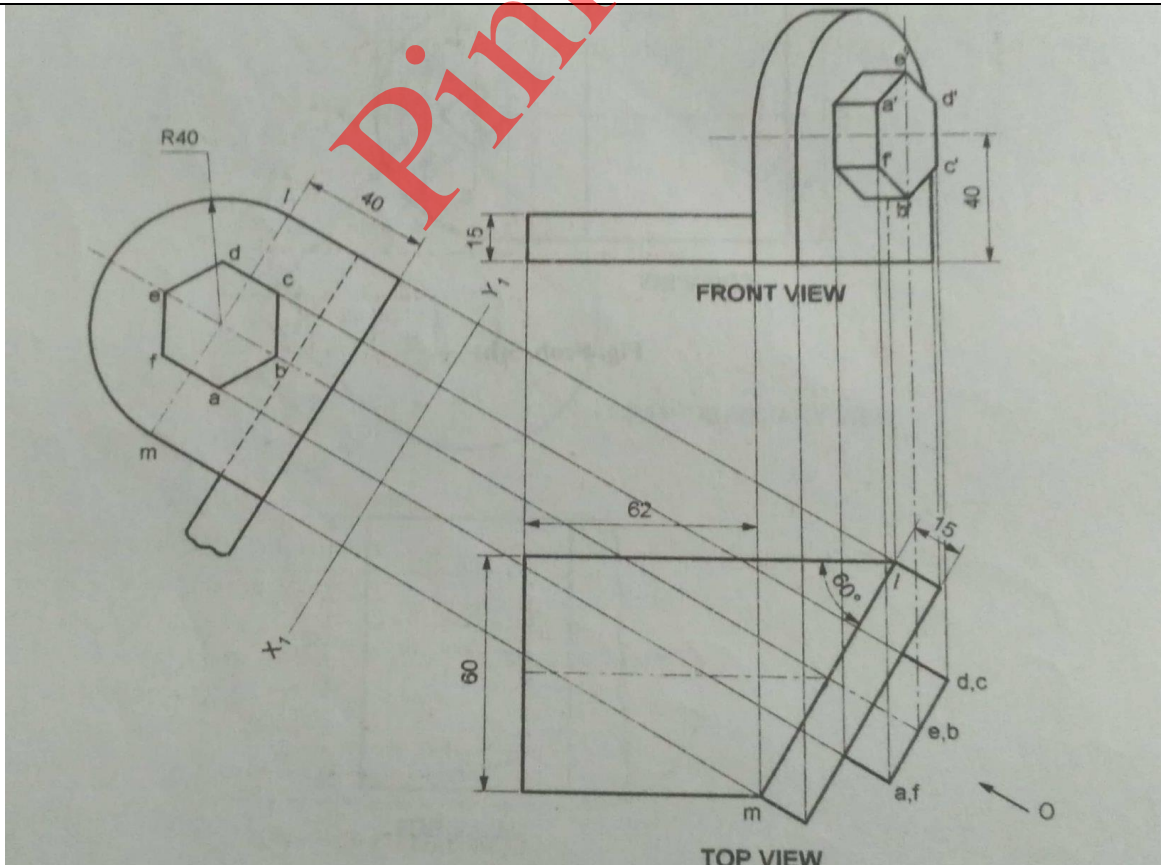

F.V. 04
Marks,
T.V. 02
Marks
and
Aux.
F.V. 02
marks

OUR CENTERS :

KALYAN | DOMBIVLI | THANE | NERUL | DADAR
Contact - 9136008228

Q. 5

a)

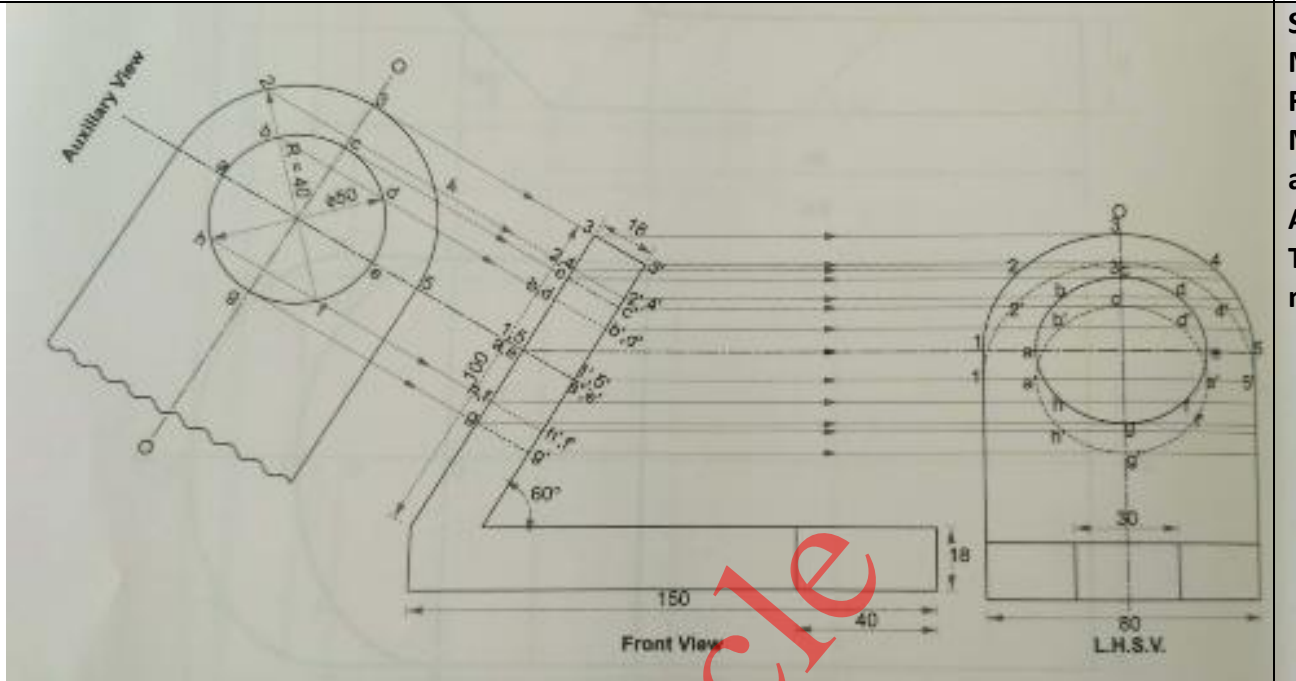

S.V. 04
Marks,
F.V. 02
Marks
and
Aux.
T.V. 02
marks

b)

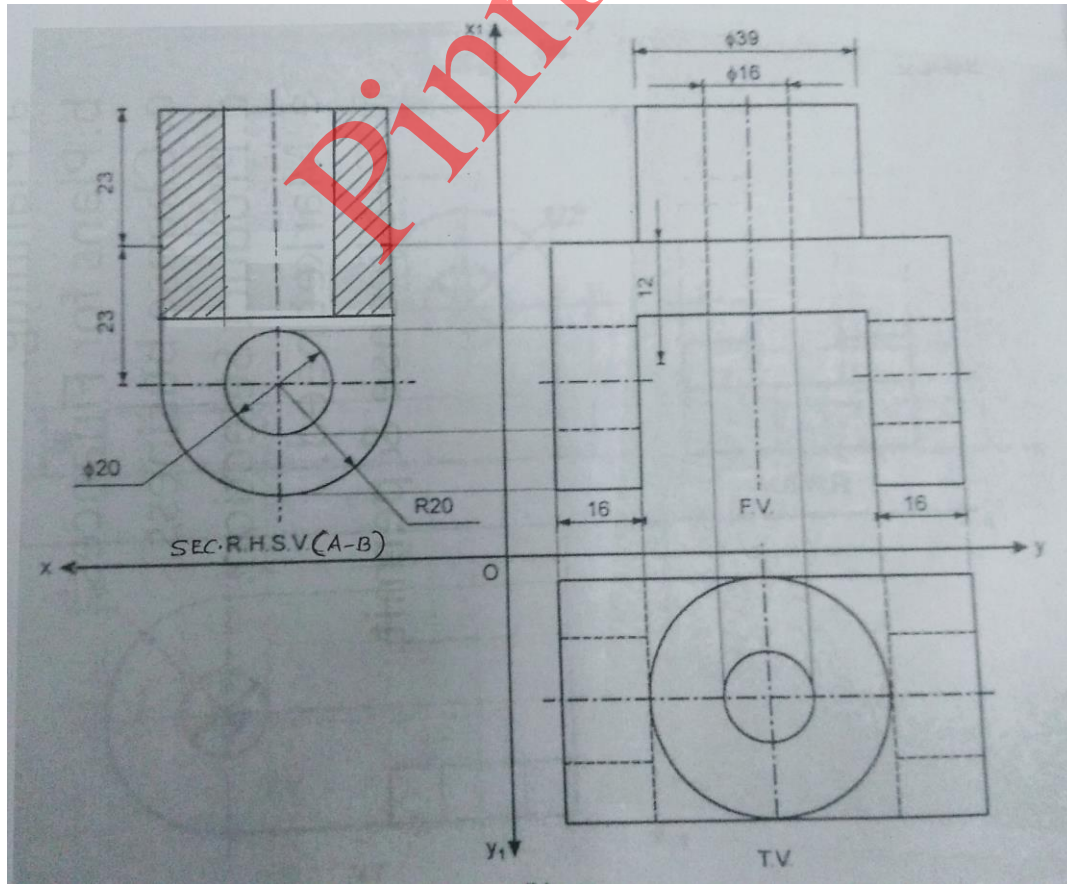

T.V. 03
Marks
F.V. 02
Marks
R.H.S.V.
. 03
Marks

OUR CENTERS :

KALYAN | DOMBIVLI | THANE | NERUL | DADAR

Contact - 9136008228

Page No: ____ / N



c)

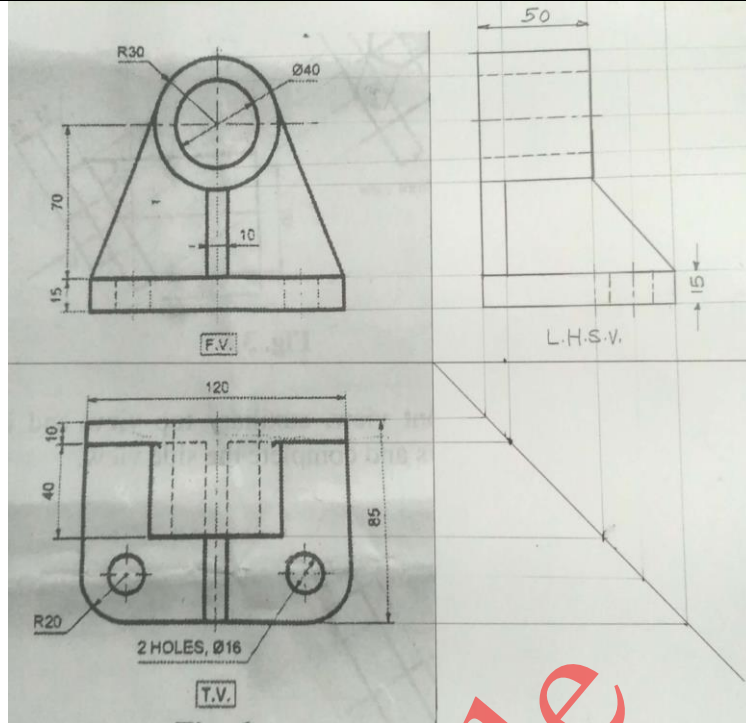

F.V. 02
Marks,
T.V. 02
Marks
and
L.H.S.V.
04
marks

Pinnacle